

Installation and Operating Instructions 0158

Lumiglas luminaire type USL 07-Ex

II 2G Ex de IIC T3/T4/T6/120°C
 II 2D Ex tD A21 IP67 T195/T130/T80/T120°C

Important, please note:

Sight glass luminaires are specifically designed and solely intended for mounting with or onto flanged sight glass fittings. Under no circumstances should a sight glass luminaire be used as a substitute for the cover flange or the complete sight/light port or as a lid or cover for vessel openings. Luminaires for use in potentially explosive environments must be mounted, installed and serviced by staff who have the relevant qualifications and have been properly trained for this type of work.

Please observe the data set out in the EC type-examination certificate!

General operating conditions:

- Independent of pressure/vacuum inside the vessel
- Approved for use in Ex environments:
Gas: Zones 1 and 2; Dust: Zones 21 and 22
- Approved for use in ambient temperatures of between -20°C and +60°C or +40°C, depending on the lamp power (see type plate and temperature classification parameters).

Electrical data, general:

- Voltage, power, temperature class and protection rating are shown on the type plate.
- Ex approval acc. to EC type-examination certificate: BVS 08 ATEX E 136
- II 2G Ex de IIC T3/T4/T6/120°C
 II 2D Ex tD A21 IP67 T195/T130/T80/T120°C
- The variant with 20 VA built-in transformer is PTC-protected; no fuse replacement necessary.
- Variants with 50 VA built-in transformer are protected by a micro-fuse (T0.315 A for 230 V/240 V; T0.630 A for 120 V).
- Power supply: AC or DC, depending on lamp fitted
- **Caution:** Only alternating current should be used for luminaires with integrated transformer or high-voltage timer.
- **Warning:** Over-voltage will cause premature lamp failure!
- 10% voltage tolerance is admissible.



Lumiglas luminaire USL 07-Ex without terminal box



Lumiglas luminaire USL 07-Ex with terminal box

Parameters/Temperature classification:

Type USL 07-Ex Variant	Nom. Voltage	Ambient temperature range							
		-20°C ≤ T _a ≤ +40°C				-20°C ≤ T _a ≤ +60°C			
		Without terminal box*		With terminal box		Without terminal box*		With terminal box	
(230 V/12 V) 20 W	230 ~	2G T6	2D T80°C	2G T6	2D T80°C	-	-	-	-
(24 V) 20 W	24 ≈	2G T6	2D T80°C	2G T6	2D T80°C	-	-	-	-
(230 V/12 V) 35 W	230 ~	2G T4	2D T130°C	2G T4	2D T130°C	-	-	-	-
(240 V/12 V) 35 W	240 ~	2G T4	2D T130°C	2G T4	2D T130°C	-	-	-	-
(12 V) 50 W	12 ≈	2G T4	2D T130°C	2G T4	2D T130°C	2G T3	2D T195°C	-	-
(24 V) 50 W	24 ≈	2G T4	2D T130°C	2G T4	2D T130°C	2G T3	2D T195°C	-	-
(24 V) 50 W FL	24 ≈	-	-	2G 120°C	2D T120°C	-	-	-	-
(120 V/12 V) 50 W	120 ~	2G T3	2D T195°C	2G T3	2D T195°C	-	-	-	-
(230 V) 50 W	230 ≈	2G T4	2D T130°C	2G T4	2D T130°C	2G T3	2D T195°C	-	-
(230 V/12 V) 50 W	230 ~	2G T4	2D T130°C	2G T4	2D T130°C	-	-	-	-
(240 V/12 V) 50 W	240 ~	2G T3	2D T195°C	2G T3	2D T195°C	-	-	-	-
(230 V) 75 W	230 ≈	2G T3	2D T195°C	2G T3	2D T195°C	-	-	-	-

* Incl. connecting cable

• **Electrical connection:**

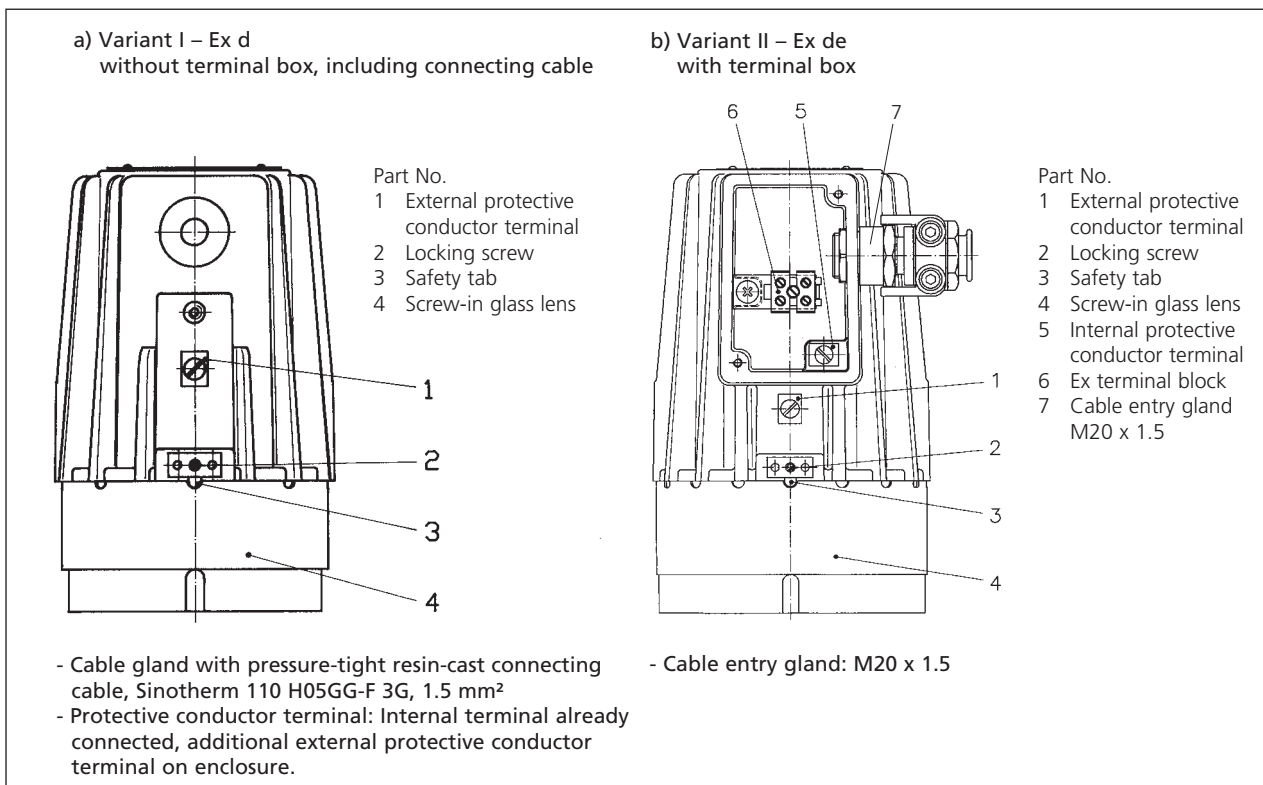

a) Variant I (without terminal box, incl. connecting cable)

- The connecting cable has been factory-installed in the luminaire and is ready for use.
- The external protective conductor terminal (1) should be connected to a separate operational earth.
- The connecting cable should be supported after a max. distance of 1 m from entry gland.
- Caution: If the cable is to be replaced (e. g. by one of a different length), the internal terminals have to be disconnected before unscrewing the cable entry gland.

Special conditions:

Ex-type luminaires that do not have a terminal box are manufactured with a permanently connected cable. If connection is carried out in a potentially explosive environment, the free ends of the connecting cable must be installed in a category 2G/2D enclosure. Prior to installation and when servicing the luminaire without a terminal box, the luminaire and the surrounding area should first be cleaned to remove any dust. During installation or servicing, the disassembled parts should be protected against dirt and dust. Before closing the lamp again, it is essential to take extra care and ensure that the inside of the luminaire is free of dust.

b) Variant II (with terminal box)

- Select a connecting cable to fit the cable entry gland M20 x 1.5.
- If the ambient temperature is greater than 40°C, heat-resistant cable, e.g. Sinotherm 110 H05GG-F3G 1.5 mm² should be used. The minimum heat resistance of the connecting cable is shown on the type plate, if applicable.
- Open the cover of the terminal box.
- Loosen strain relief screws with anti-twist tabs on the cable gland assembly.
- Insert cable, seal, tighten screws again.

- Wire to Ex terminal block (6); max. cross-section 2.5 mm²; protective conductor to terminal (5, internal). The external protective terminal (1) must be connected to a separate operational earth.
- Check that the gasket is in the correct position in the cover; adjust if necessary!
- Close lid of terminal box, making sure the gasket is in place.

• **Replacing lamp:**

- Switch off power
- Allow sufficient time to cool down, see type plate.
- Undo locking screw (2) which releases the safety tab (3) for the screw-type glass lens (4).
- Unscrew glass lens (4) using only the special claw spanner.
- The defective lamp is then pulled out (2-pin type), or removed with a press-and-twist movement (GZ10 bayonet type).
- Hold the new lamp bulb (original products only, please) using a protective cloth, taking care not to touch it with your bare fingers. Carefully insert the replacement lamp: push the 2-pin bulb into its socket, push-and-twist bayonet type lamps. Make sure the lamp is securely in position!
- Before closing the luminaire, re-lubricate the thread of the screw lens (e. g. with AEMA-SOL 6 B, from A. E. Matthes).
- Refit the glass lens (4) by screwing it into place until it is tight again (pressure on O-ring).
- The glass lens (4) is locked into position once the safety locking tab (3) engages in one of the notches.
- Retighten the locking screw (2).
- Switch on power again.

• **Warning:**

When replacing lamp bulbs, make sure that the light beam is evenly distributed over the glass lens as prescribed by the design. On no account should a "hot spot" be allowed to occur outside the luminaire (caused e. g. by the incorrect position or condition of the lamp).

Mechanical installation:

With circular sight glass fittings or visual flow indicators, the luminaire is attached to the cover flange using the hinged bracket. With the screw-type sight glass fitting, the luminaire is attached to the slotted cover nut; alternatively, it can be mounted using a hinged bracket or a flanged adapter collar.

- The Lumiglas luminaire Type USL 07-Ex is suitable for sight glasses in the following nominal sizes using the appropriate mounting:

type of fitting	from DN	Hinged bracket	Flanged adapter collar
Circular sightglass fitting			
DIN 28120	50 ...	+	-
DIN 28121	50 ...	+	-
Visual flow indicator	50 ...	+	-
Screw-type sightglass fitting	65	-	+
	80	-	+
similar to DIN 11851	100	-	+
	125	+	+

Attachment with luminaire mounting:

The luminaire is attached to the cover flange of a circular sight glass unit or flow indicator or to the slotted cover nut of screw-type sight glass fittings to DIN 11851 using the mounting parts – straight or angular bracket.
 Straight bracket for DN 50 to 100
 Angular bracket for DN 125 to 200

Mounting with flanged adapter collar:

The flanged adapter collar is bolted or welded to the slotted cover nut (DIN 11851).

- Please note:** Fasteners and claw spanner should be ordered separately, if required.

Replacement parts:

Screw-type lens (light aperture)	Part No. 1774.038.00
Reflector, spot	5904.049.00
Reflector, flood	5904.050.00
O-ring seal (Viton)	0862.040.00
Lamp socket G 4 (2-pin)	1202.011.00
Lamp socket GY 6.35 (2-pin)	1202.012.00
Lamp socket GZ 10	1202.024.00

Flat gasket for terminal box cover 0854.058.00

Cable entry gland:

complete with 2 m connecting cable	1084.013.00
complete with 5 m connecting cable	1084.015.00
complete with 20 m connecting cable	1084.017.00

Flared cable entry gland (M20 x 1.5) 9108.008.00

(Halogen) lamps:

12 V/20 W – GY6.35	3232.240.00
24 V/20 W – G4	3232.206.00
12 V/35 W – GY6.35	3232.232.00
12 V/50 W – GY6.35	3232.238.00
24 V/50 W – GY6.35	3232.242.00
230 V/50 W – GZ10	3232.261.00
230 V/75 W – GZ10	3232.263.00

Accessories:

Claw spanner 6805.002.00

Servicing:

- Keep luminaire clean and free of dust.
- Keep note of average lamp life.
- Use only original replacement parts.

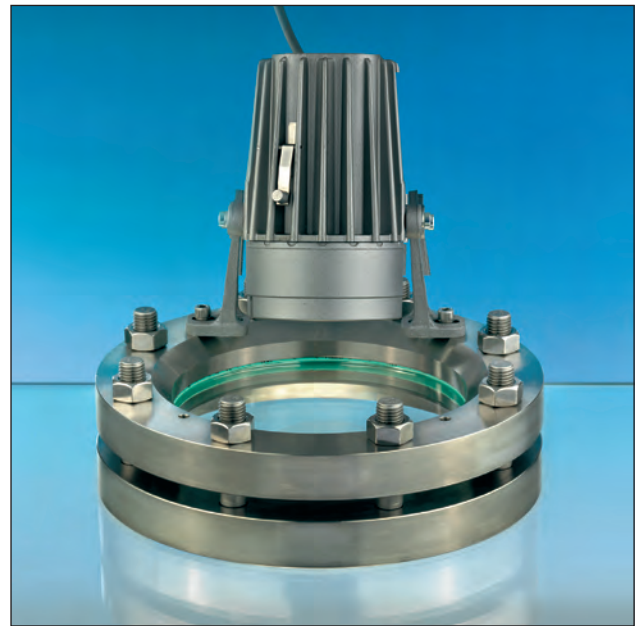

Application as combined sight and light port on a sight glass fitting acc. to DIN 28120, mounting by way of hinged bracket

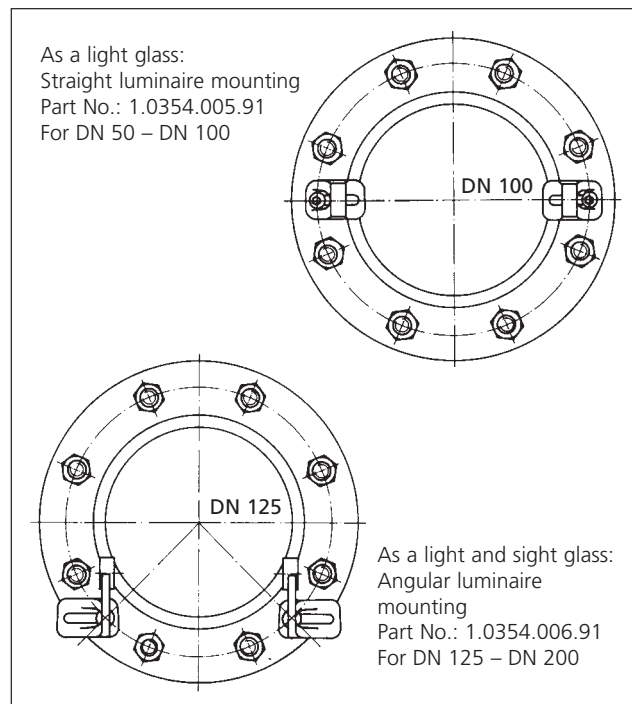

Combination options

