

Installation and Operating Instructions 0158

Lumiglas luminaire stainless steel type ESL 26-Ex

II 2G Ex de IIC T3/T4
II 2D Ex tD A21 IP67 T195/T130°C

Important, please note:

Sightglass luminaires are specifically designed and solely intended for mounting with or onto flanged sightglass fittings. Under no circumstances should sightglass luminaires be used as a substitute for the cover flange or the complete sight/light port or as a lid or cover for vessel openings. Luminaires for use in potentially explosive environments must be mounted, installed and serviced by staff who have the relevant qualifications and have been properly trained for this type of work.

Please observe the data set out in the EC type-examination certificate!

General operating conditions:

- Independent of pressure/vacuum in the vessel
- Approved for use in Ex environments:
 - Gas: Zones 1 and 2
 - Dust: Zones 21 and 22
- **Approved for use in ambient temperatures of between -20°C and +60°C or +40°C, depending on the lamp power (see type plate and temperature classification parameters).**

Electrical data, general:

- Voltage, power, temperature class and protection rating are shown on the type plate.
- Ex approval acc. to EC type-examination certificate: BVS 08 ATEX E 138
- II 2G Ex de IIC T3/T4
 II 2D Ex tD A21 IP67 T195/T130°C
- The variant with integrated transformer is PTC-protected; no fuse replacement necessary.
- Power supply: AC or DC, depending on lamp fitted
- **Caution:** Only alternating current should be used on luminaires with integrated transformer or high-voltage timer.
- **Warning:** Over-voltage will cause premature lamp failure!
- 10% voltage tolerance is admissible.

Parameters/Temperature classification:

Type ESL 26-Ex Variant	Nominal Voltage	Ambient temperature range			
		$-20^{\circ}\text{C} \leq T_a \leq +40^{\circ}\text{C}$		$-20^{\circ}\text{C} \leq T_a \leq +60^{\circ}\text{C}$	
(12 V) 20 W	12 ≈	2G T4	2D T130°C	2G T4	2D T130°C
(24 V) 20 W	24 ≈	2G T4	2D T130°C	2G T4	2D T130°C
(120 V/12 V) 20 W	120 ~	2G T4	2D T130°C	2G T4	2D T130°C
(230 V/12 V) 20 W	230 ~	2G T4	2D T130°C	2G T4	2D T130°C
(240 V/12 V) 20 W	240 ~	2G T4	2D T130°C	2G T4	2D T130°C
(12 V) 35 W	12 ≈	2G T4	2D T130°C	-	-
(230 V) 40 W	230 ≈	2G T3	2D T195°C	-	-
(12 V) 50 W	12 ≈	2G T3	2D T195°C	-	-
(24 V) 50 W	24 ≈	2G T3	2D T195°C	-	-
(230 V) 50 W ¹⁾	230 ≈	2G T4	2D T130°C	-	-
(230 V) 50 W ²⁾	230 ≈	2G T3	2D T195°C	-	-

¹⁾ GZ10 ²⁾ E27

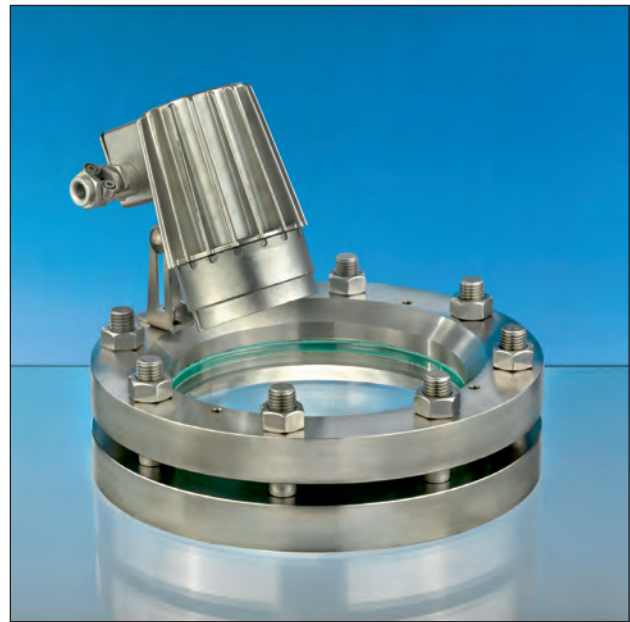

Application as combined sight and light port on a sightglass fitting acc. to DIN 28120, mounting by way of hinged bracket

• Electrical connection:

- Select a connecting cable to match the cable entry gland M20 x 1.5. If the ambient temperature is greater than 40°C, heat-resistant cable, e.g. Sinotherm 110 H05GG-F3G 1.5 mm² should be used. The minimum heat resistance of the connecting cable is shown on the type plate, if applicable.
- Open the cover of the terminal box.
- Loosen strain relief screws with anti-twist tabs on the cable gland assembly.
- Insert cable, seal, tighten screws again.
- Wire to Ex terminal block (6); max. cross-section 2.5 mm²; protective conductor to terminal (5, internal). The external protective terminal (1) must be connected to a separate operational earth.
- Check that gasket is in the correct position in the cover; adjust if necessary!
- Close terminal box with cover complete with gasket.

• Replacing lamp:

- Switch off power
- Allow sufficient time to cool down, see type plate.
- Undo locking screw (2) which releases the safety tab (3) for the screw-type glass lens (4).
- Unscrew glass lens (4) using only the special claw spanner.
- The defective lamp is then pulled out (2-pin type), or unscrewed (E14 or E27), or removed with a press-and-twist movement (GZ10 bayonet type).
- Hold the new lamp bulb (original products only, please) using a protective cloth – taking care not to touch it with your bare fingers. Carefully insert the replacement lamp: push the 2-pin bulb into its socket, screw in the E14 or E17 lamp, push-and-twist bayonet type lamps. Make sure the lamp is securely in position!
- Before closing the luminaire, relubricate the thread of the screw lens (e.g. with AEMA-SOL 6 B, from A. E. Matthes).
- Refit the glass lens (4) by screwing it into place until it is tight again (pressure on O-ring).
- The glass lens (4) is locked into position once the safety locking tab (3) engages in one of the notches.
- Retighten the locking screw (2).
- Switch on power again.

• Warning:

When replacing lamp bulbs, make sure that the light beam is evenly distributed over the glass lens. On no account should a "hot spot" be allowed to occur outside the luminaire (caused e.g. by incorrect position or condition of the lamp).

• Mechanical installation:

With the circular sightglass fitting or visual flow indicator the luminaire is attached to the cover flange using the hinged bracket. With the screw-type sightglass fitting, the luminaire is attached to the slotted cover nut; alternatively, it can be mounted using a hinged bracket or a flanged adapter collar.

• The Lumiglas luminaire Type ESL26-Ex is suitable for sightglasses in the following nominal sizes, using the appropriate mounting:

Type of fitting	from DN	Hinged bracket	Flanged adapter collar
Circular sightglass fitting			
DIN 28120	50 ...	+	-
DIN 28121	50 ...	+	-
Visual flow indicator	50 ...	+	-
Screw-type sightglass fitting similar to DIN 11851	65	-	+
	80	+	+
	100	+	+
	125	+	-

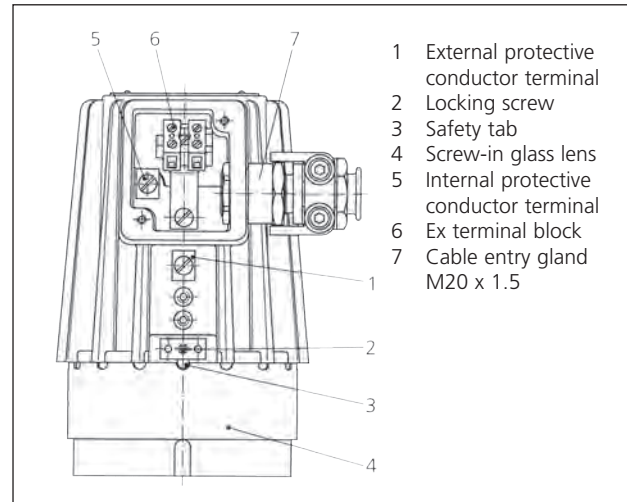

• Mounting with hinged bracket:

The hinged bracket is used to secure the luminaire to the cover flange of a circular sightglass unit (also suitable for visual flow indicators). Alternatively, it can be attached to the slotted cover nut of screw-type sightglass fittings to DIN 11851.

The bracket is fixed in place by turning the supplied M8 bolt into a blind hole which has previously been tapped in the pitch circle of the cover flange face. An additional option is to weld the bracket on.

• Mounting with flanged adapter collar:

The flanged adapter collar is bolted or welded to the slotted cover nut (DIN 11851).

• Please note:

Fastening and mounting elements, claw spanner, etc. should be ordered separately if not available.

• Replacement parts:

	Part No.
Screw-type lens (light aperture)	1774.043.00
Reflector, spot	5904.047.00
Reflector, flood	5904.048.00
O-ring seal (Viton)	0862.039.00
Lamp socket G 4 (2-pin)	1202.011.00
Lamp socket GY 6.35 (2-pin)	1202.012.00
Lamp socket GZ 10	1202.024.00
Lamp socket E 14	1202.022.00
Lamp socket E 27	1202.019.00
Flat gasket, terminal box cover	0854.038.00
Flared cable entry gland (M20 x 1.5)	9108.009.00

(Halogen) lamps:

12 V/20 W – GY6.35	3232.240.00
24 V/20 W – G4	3232.206.00
24 V/20 W – G4 (reflector spot lamp)	3232.222.00
12 V/35 W – GY6.35	3232.232.00
12 V/50 W – GY6.35	3232.238.00
24 V/50 W – GY6.35	3232.242.00
230 V/50 W – GZ10	3232.261.00
230 V/40 W, PAR16 – E14	3232.256.00
230 V/50 W, PAR20 – E27	3232.241.00

• Accessories:

Claw spanner 6805.001.00

• Servicing:

- Keep luminaire clean
- Keep note of average lamp life
- Use only original replacement parts