

APPLICATION DATA SHEET

WWW.OLIVER-IGD.CO.UK



Control Systems

Transmitters

Sensors

Accessories

TOCSIN 102C Hazardous Area Camera



- ATEX Certified
- Compact Size Allowing Installation In All Locations.
- Sealed To IP67
- Corrosion Resistant Stainless Steel Housing
- High Resolution High Sensitivity CCD Sensor
- No Image Burn No Adjustments
- Auto Iris For Day To Night Operation
- Easily Installed By Untrained Personnel
- Fully Adjustable Mounting Base

With an overall diameter of just 50mm and a length of 80mm, the T102C is both compact and easy to integrate, featuring standard video outputs and 24V DC operation. Constructed in stainless steel and featuring a sapphire window, the T102C is sealed to IP66 and is therefore suitable for use in a range of arduous applications including; safety, security and process monitoring.

Ex d IIC T6 Gb
Ex tb IIIC T6 Db IP66
Ta = -20 C to +55 C
CE 0518
Ex II 2 GD
Sira 02ATEX1271X

Specification

Specification	Units	Min	Max
Supply Voltage Range	V	19	32
Supply Reverse Protection	V	--	-36
Supply Over voltage protection	V	--	36
Supply Power Consumption	mW	--	1200
Video Signal Output (coax)	Vpp	1	Composite into 75R
Over voltage protection	V	--	36
Video Sensor	--	Full Colour 1/4" DSP Colour CCD	
Horizontal Resolution	Lines		380
Picture Element (Pixels)	Pixels	N:290K P:320K	
Light Sensitivity	Lux	0.5Lux F2	--
Signal to Noise Ratio	db	50	--
Focus		Fixed	
Iris	Sec	Automatic 1/50,1/60, - 1/100000 sec	
Housing Construction	--	Stainless Steel 316L, Sapphire Window	
Dimensions	mm	50mm Dia x 80mm	
Weight	kg	--	0.5
Ingress Protection	IP	--	67
Operating Temperature Range	C	-20	55
Operating Humidity Range	%RH	0	99
Connections		Made in junction box	



International Gas Detectors
CH₄ H₂S CO₂
NO NO₂ SO₂



Pepper Road
Bramhall Technology Parl
Stockport
SK7 5BW
England

Tel: +44 (0)161 483 1415
Fax: +44 (0) 161 484 2345
Email: sales@oliver-igd.co.uk
Website: www.oliver-igd.co.uk



023827
Ref ROS72
page 1 of 5

TOCSIN 102C

Hazardous Area Camera

CCTV Systems for Industrial and Marine Applications

The Tocsin 102 CCTV camera is capable of standalone operation for surveillance and hazard management duties as well as integration with other site systems including process control, Fire & Gas, ESD and intruder alarms. Numerous businesses benefit from CCTV technology in industrial, hazardous area and marine environments, such as:

Plant, Petrochemical/Refineries, Pharmaceutical, Industrial

Typical applications include offshore installations, refineries, tank farms, jetties and terminals, Flare monitoring, Loading/unloading racks, Marine docks, Pump/compressor stations, Wastewater treatment, Gates and entry ways.



Offshore Oil & Gas Installations

CCTV equipment developed specifically for the offshore market and built to resist the most corrosive environment and permit quick replacement. Typical applications include surveillance of Flare, BOP, Racker, Pipe deck, Derrick operations, Helideck, Cranes, Generator & Engine Rooms, Mud pump equipment, Shale shakers,

Marine

Applications include LNG/LPG tankers, crude oil tankers. Seismic, cable layers, container and naval vessels. Surveillance areas are engine rooms, cargo handling & mooring, pump & compressor rooms and underwater mating for shuttle tankers.

Pulp/Paper Mills

Typical applications include surveillance of Woodyards, Scales, Cranes, Debarker drum, Conveyors, Chip screens, Reclaimer, Truck dumpers.

Mill Operations

Typical applications include surveillance of Filter decks & washers, Liquor unloading stations, Wastewater treatment, Paper machine inspection points, Bulk material handling, Gates & entry ways.



International Gas Detectors
CH₄ H₂S CO₂
NO₂ NO SO₂



Pepper Road
Bramhall Technology Parl
Stockport
SK7 5BW
England

Tel: +44 (0)161 483 1415
Fax: +44 (0) 161 484 2345
Email: sales@oliver-igd.co.uk
Website: www.oliver-igd.co.uk



023827
Ref ROS72
page 2 of 5

TOCSIN 102C

Hazardous Area Cameras & Accessories

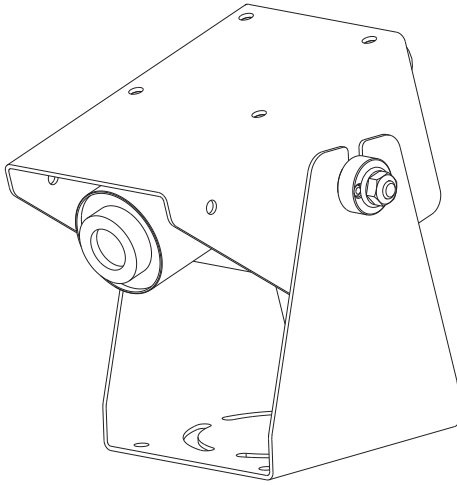

Camera Part Number	Lens Option (f)
5121901	2.9mm
5114901	3.6mm
5122001	4.3mm
5122101	6.0mm
5122201	8.0mm
5122301	12.0mm
5122401	16.0mm
Accessory	Part Number
Universal Mounting Bracket	5078701
Junction Box	5045801
Anti-Glare Shield	5126001
Air Blow Adapter	5127001

Camera Lens Selection

The standard camera lens option is 3.6mm and will cover the majority of applications. It is advisable for a new application to check that the standard 3.6mm lens option is correct. Normally with a fixed format camera there will be a specific item or area that is under surveillance. The lens option is calculated from having a rough idea of the height or width of this object and its proposed distance from the camera. The following formulas can then be applied for selection. It must be remembered that with any camera there is only a certain resolution available when viewed on the monitor. It is therefore important that the area of importance to be viewed makes maximum use of that resolution. The lens options listed can also be factory set for a particular 'best picture' distance for a given depth of field. Applications should be referred to Oliver IGD Ltd for advice on selection for best performance.

For Known Object Height

$$f = 2.4 \times \text{Distance to Object} / \text{Height of Object}$$

Camera is to be mounted 8M from an object 2.2M high

$$f = 2.4 \times 8 / 2.2 = 8.7 \quad \text{Nearest Lens Option P/N 5122201 (f8.0)}$$

For Known Object Width

$$f = 3.4 \times \text{Distance to Object} / \text{Width of Object}$$

Camera is to be mounted 7M from an object 6.5M wide

$$f = 3.4 \times 7 / 6.5 = 3.7 \quad \text{Nearest Lens Option P/N 5114901 (f3.6)}$$



International Gas Detectors

CH₄ H₂S CO₂
NO₂ NO SO



Pepper Road
Bramhall Technology Parl
Stockport
SK7 5BW
England

Tel: +44 (0)161 483 1415
Fax: +44 (0) 161 484 2345
Email: sales@oliver-igd.co.uk
Website: www.oliver-igd.co.uk



023827
Ref ROS72
page 3 of 5

TOCSIN 102C

Hazardous Area Cameras & Accessories

Power Supply Units

Power up to 16 cameras from this switch mode power supply unit.

- 230/110V AC 50/60Hz Operation
- Rear Panel Cable Connections

Part Number 5125001



Camera Control/Video Capture

Digital storage and data control for up to 16 cameras.

Key Features:

- Time-Lapse VCR + Multiplexer
- 4 Audio inputs / 2 Audio outputs
- 4 level video recording quality: Best / High / Normal /Basic
- On Screen Display and RTC (Real time clock) Function
- Record or display real-time recorded images.
- Independent main monitor and call monitor outputs allow
- Simultaneous multi-camera or full screen viewing
- Picture-In-Picture in live and playback modes
- Independent title generation (up to 6 characters).
- Call monitor for sequence display
- Support 2 Removable HDDs, IDE Type
- Timer schedule recording.
- Record refresh rate up to 12 IPS.
- Quick Multiple Search by date/time, alarm or full list.
- Security password protection

Part Number 5124901



Video capture technology is changing all the time. If the option shown here does not match your application then please contact Oliver IGD sales staff who will help in selecting the most applicable control technology.

Monitors

14" CCTV Colour Monitor from Hitachi, metal cased

P/N 5128001

Cables

Oliver IGD cameras require a 75 Ohm signal cable and two power lines. It is important to remember that the cable must suit the area of intended camera operation.

Our standard cable P/N 5127001 supplied per Meter

Please contact Oliver IGD with your requirement.



International Gas Detectors

CH₄ H₂S CO₂
NO₂ SO₂ NO SO



Pepper Road
Bramhall Technology Parl
Stockport
SK7 5BW
England

Tel: +44 (0)161 483 1415
Fax: +44 (0) 161 484 2345
Email: sales@oliver-igd.co.uk
Website: www.oliver-igd.co.uk



023827
Ref ROS72
Page 4 of 5

TOCSIN 102C

Hazardous Area Camera Overview Drawing

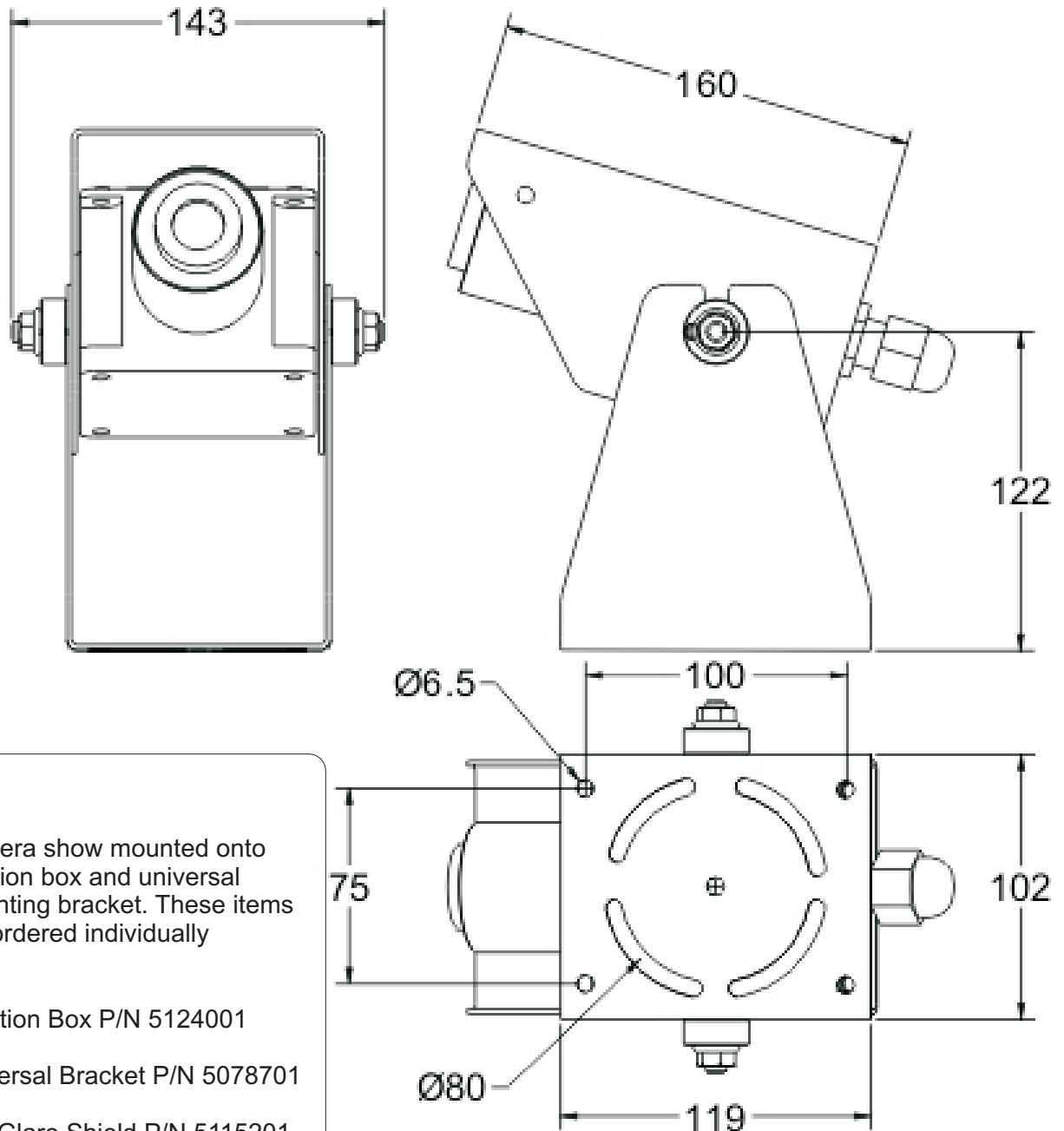

Note

Camera shown mounted onto junction box and universal mounting bracket. These items are ordered individually

Junction Box P/N 5124001

Universal Bracket P/N 5078701

Anti Glare Shield P/N 5115201

Airblow Adaptor P/N 5127001