

DS1505



Aspiratore compatto e versatile dotato di apparato aspirante con turbina a canale laterale installata direttamente sulla testa della macchina, consente la raccolta di materiali diversi, solidi, polverosi, e idoneo ad un lavoro continuativo, grazie all'utilizzo di un filtro a tasche dotato di una grande superficie filtrante. Con l'aggiunta del galleggiante nel contenitore risulta idoneo alla raccolta dei liquidi.

Compact vacuum unit details equipped with a side channel pump installed directly on the top of the machine. It is suitable to collect many types of solid, and dusty materials. It can work continuously with the addition of a liquid sensor, this vacuum cleaner is also able to collect liquids.

CARATTERISTICHE TECNICHE - TECHNICAL DATA

		DS1505M	DS1505
Potenza - Power	kW	2,2 (2,2 230V)	3
Corrente - Rated current	A	4 (15)	7
Tensione alimentazione - Voltage	V - Hz	200/240 - 50	400 - 50
Max Portata aria - Airflow max.	mc/h	300	300
Max vuoto - Vacuum max.	mmH ₂ O	3000	3000
Capacità raccolta - Container	lt	55	55
Filtro primario - Main filter	cmq	14500	14500
Filtro sicurezza - Safety filter	cmq	15000	15000
Scuotitore - Shaker	-	-	-
Bocca aspirazione - Suction inlet	mm	70-50	70-50
Rumorosità - Noise level	dB(A)	75	75
Dimensioni - Dimension	mm	765x745x1635	765x745x1635
Peso - Weight	kg	95	95

Varianti costruttive:
 Cartuccia di sicurezza Hepa classe H13.
 Tensioni diverse.
 Monofase da 200/240V industriale.
 Corpo acciaio Inox
 Versione ATEX

Versions:
Cartridge safety filter Hepa class H13
Specials voltages
Industrial single phase motor 200/240V
Stainless steel body.
ATEX version

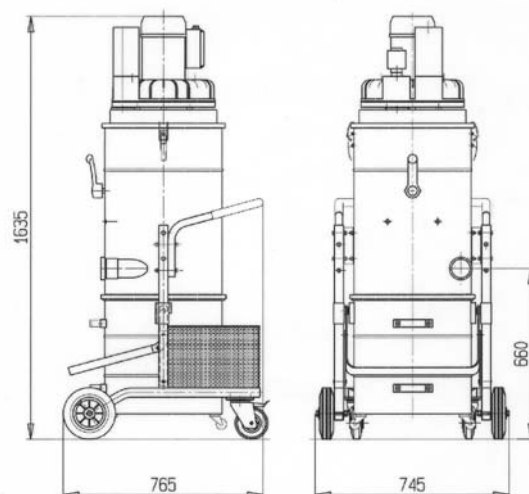



COMM-CO

Aspiratori Industriali - Vacuum cleaners

IDONEITA' - SUITABILITY

	Sfridi Scraps	Trucioli scaglie leggere Light chips	Polvere Dust	Trucioli scaglie pesanti Heavy chips	Granulati Cereali Cereals	Graniglia Sabbie fonderia Sand Molding sand	Oli Limature oleose Oil Sludge	Liquidi Liquids	Grassi Addensanti Heavy grease	Ovatta Wadding
DS1505										

Limitato/Restricted



Idoneo/Suitable



Eccellente/Excellent



PERFORMANCES

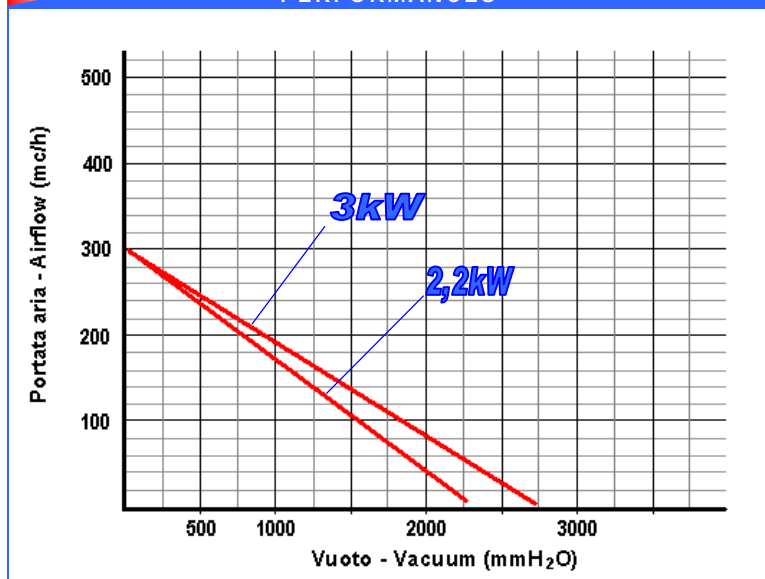

DS1505 ATEX



Ex II 3D T125°C IP55



ATEX



Versione ATEX in accordo alle norme:
 EN50014 – EN50018
 Interruttore IP65
 Cavi armati
 Continuità elettrica B1
 Protezione alle polveri con capottatura ausiliaria

Atex version according to :
 EN50014 – EN50018
 IP65 starter
 Shilded electrical cable
 B1 ground conductivity
 Cap dust protection

Company Info:

Comm-Co

Kreekzoom 9

4561 GX Hulst

The Netherlands

Tel:31114-370030

Fax: +31114-370029

E-mail: Info@comm-co.com

Website: http://www.comm-co.com

Webshop: http://www.ecomshop.com

www.atexshop.com

www.ruggedshop.nl

www.webpainter.nl

www.wavecomblog.com

www.eyecctv.nl