

The **BR385** is a third generation intrinsically safe field mounting sounder which supersedes the BA385-IIC and BA385-IIB. The new sounder, which produces a loud audible warning signal in a hazardous area has forty nine different first stage alarm sounds selectable by internal switches. Each first stage tone can be changed to a second or a third stage alarm sound by an external contact which may be in the safe or hazardous area. Selectable outputs include DIN, NFS, PFEER, Australian and Singaporean defined warning, alert and evacuation tones.

Main application of the BR385 sounder is the generation of unique audible warnings within a hazardous area. The sounder may be powered from a wide range of Zener barriers or galvanic isolators and may be controlled by any contact or dc supply in the safe area. The BR385 may also be switched in the hazardous area by an intrinsically safe relay, or any equipment with an intrinsically safe, simple apparatus switch output, such as a BEKA Intrinsically safe loop powered indicator or a serial text display.

The selected first stage tone can be changed to a different second or third stage tone by inter-connecting sounder terminals using a switch contact, which may be in the safe or hazardous area. This enables one sounder to announce up to three different conditions, for example, alarms warning, alarm and automatic shut-down.

A crystal controlled oscillator accurately defines the frequency and repetition rate of each alarm signal. This ensures that when multiple BR385 sounders are activated at the same time the output tones from all the sounders remain synchronised.

ATEX, IECEx and FM intrinsic safety certification permits installation in all gas hazardous zones and all gas groups. Input safety parameters allow use with a wide range of Zener barriers and galvanic isolators, and zero output parameters simplify intrinsic safety system design.

A BA386 LED flashing beacon may be powered from the same Zener barrier or galvanic isolator as the sounder. This significantly reduces installation costs of a combined sounder and beacon system and includes an alarm accept function, while only marginally reducing the sound output, but may only be used for ATEX systems. See the BA386 datasheet for full information.

The robust ABS enclosure which is flame-retardant provides IP66 protection and is suitable for external mounting. Cable entry is via a single untapped hole which will accept a 20mm gland or conduit fitting. A 20mm knock-out is also provided in the rear of the enclosure.

The BR385 contains overvoltage protection to prevent damage during commissioning and to allow the sounder to be tested in a safe area without the need for a Zener barrier or galvanic isolator.

BR385

Audible Sounder

Intrinsically safe for use in all gas hazardous areas

- ◆ ATEX, IECEx & FM certification.
- ◆ 49 first stage, 21 second stage & 9 third stage alarm sounds.
- ◆ PFEER compliant
- ◆ Up to 103dB(A) output.
- ◆ Input overload protection.
- ◆ Volume control
- ◆ IP66 enclosure
- ◆ Can be powered from BA386 flashing beacon.

COMM-CO
Communication today and tomorrow

SPECIFICATION

Power supply

Voltage 16V min via 28V 93mA Zener barrier
8 to 28V between – and + terminals.
Not damaged by direct connection to the supply without a Zener barrier or galvanic isolator in circuit.

Current 25mA typical when powered from 24Vdc via a 28V, 93mA Zener barrier.

Second and third stage alarms

Second stage Connect terminal S2 to ‘-’ terminal*
Third stage Connect terminal S3 to ‘-’ terminal*
* If diode return barrier is used voltage drop must be less than 0.9V.

Output

Sound level at 1m Up to 103dB(A)
Volume control 15dB(A) level reduction

Intrinsic safety

Europe ATEX Code Group II Category 1G
Ex ia IIC T4 Ga
Ta -40 to 60C
Sira06ATEX2032X
The BR385 may be powered from any ATEX certified Zener barrier or galvanic isolator whose output parameters do not exceed:

U_o = 28Vdc
I_o = 93mA
P_o = 0.66W

Location Zone 0, 1 or 2

USA FM

Standard 3610 Entity
Code CLI, Div. 1, Gp A, B, C, and D
CLI Zone 0 AEx ia IIC
Temperature code T4 at 60°C
File No. 3027157

International IECEx

Code Ex ia IIC T4 Ga
-40°C ≤ Ta ≤ +60°C
IECEX SIR 17.0014X
Temperature code

Tone Number		Switch Settings 1 2 3 4 5 6	Second Stage Alarm	Third Stage Alarm
Tone 1	Continuous 340Hz	0 0 0 0 0	Tone 2	Tone 5
Tone 2	Alternating 800/1000Hz @ 0.25s intervals	1 0 0 0 0	Tone 17	Tone 5
Tone 3	Slow whoop 500/1200Hz @ 0.3Hz with 0.5s gap repeated	0 1 0 0 0	Tone 2	Tone 5
Tone 4	Sweeping 500/1000Hz @ 1Hz	1 1 0 0 0	Tone 6	Tone 5
Tone 5	Continuous 2400Hz	0 0 1 0 0	Tone 3	Tone 20
Tone 6	Sweeping 2400/2900Hz @ 7Hz	1 0 1 0 0	Tone 7	Tone 5
Tone 7	Sweeping 2400/2900Hz @ 1Hz	0 1 1 0 0	Tone 10	Tone 5
Tone 8	Siren 500/1200/500Hz @ 0.3Hz	1 1 1 0 0	Tone 2	Tone 5
Tone 9	Sawtooth 1200/500Hz @ 1Hz - D.I.N	0 0 0 1 0	Tone 15	Tone 2
Tone 10	Alternating 2400/2900Hz @ 2Hz	1 0 0 1 0	Tone 7	Tone 5
Tone 11	Intermittent 1000Hz @ 1Hz	0 1 0 1 0	Tone 2	Tone 5
Tone 12	Alternating 800/1000Hz @ 0.875Hz	1 1 0 1 0	Tone 4	Tone 5
Tone 13	Intermittent 2400Hz @ 1Hz	0 0 1 1 0	Tone 15	Tone 5
Tone 14	Intermittent 800Hz 0.25s ON, 1s OFF	1 0 1 1 0	Tone 4	Tone 5
Tone 15	Continuous 800Hz	0 1 1 1 0	Tone 2	Tone 5
Tone 16	Intermittent 660Hz 150Ns ON, 150ms OFF	1 1 1 1 0	Tone 18	Tone 5
Tone 17	Alternating 544Hz (100ms) / 440Hz (400ms) - NFS 32-001	0 0 0 0 1	Tone 2	Tone 27
Tone 18	Intermittent 660Hz 1.8s ON, 1.8s OFF	1 0 0 0 1	Tone 2	Tone 5
Tone 19	Sweep 1400Hz to 1600Hz up 1s 1600Hz to 1400Hz down 0.5s	0 1 0 0 1	Tone 2	Tone 5
Tone 20	Continuous 660Hz	1 1 0 0 1	Tone 2	Tone 5
Tone 21	Alternating 554/440Hz @ 1Hz	0 0 1 0 1	Tone 2	Tone 5
Tone 22	Intermittent 544Hz @ 0.875Hz	1 0 1 0 1	Tone 2	Tone 5
Tone 23	Intermittent 800Hz @ 2Hz	0 1 1 0 1	Tone 6	Tone 5
Tone 24	Sweeping 800/1000Hz @ 50Hz	1 1 1 0 1	Tone 29	Tone 5
Tone 25	Sweeping 2400/2900Hz @ 50Hz	0 0 0 1 1	Tone 29	Tone 5
Tone 26	Simulated bell	1 0 0 1 1	Tone 2	Tone 15
Tone 27	Continuous 554Hz	0 1 0 1 1	Tone 26	Tone 5
Tone 28	Continuous 440Hz	1 1 0 1 1	Tone 2	Tone 5
Tone 29	Sweeping 800/1000Hz @ 7Hz	0 0 1 1 1	Tone 7	Tone 5
Tone 30	Continuous 300Hz	1 0 1 1 1	Tone 2	Tone 5
Tone 31	Sweeping 660/1200 @ 1Hz	0 1 1 1 1	Tone 26	Tone 5
Tone 32	Two Tone Chime	1 1 1 1 1	Tone 26	Tone 15
Tone 33	Intermittent 745Hz	0 0 0 0 1	Tone 2	Tone 5
Tone 34	Alternating 1000/2000Hz @ 0.5s - Singapore	1 0 0 0 1	Tone 38	Tone 45
Tone 35	420Hz @ 0.625s - Australian Alert	0 1 0 0 1	Tone 36	Tone 5
Tone 36	500-1200Hz 3.75s / 0.25s - Australian Evacuative	1 1 0 0 1	Tone 35	Tone 5
Tone 37	Continuous 1000Hz	0 0 1 0 1	Tone 9	Tone 45
Tone 38	Continuous 2000Hz	1 0 1 0 1	Tone 34	Tone 45
Tone 39	Intermittent 800Hz 0.25s ON 1s OFF	0 1 1 0 1	Tone 23	Tone 17
Tone 40	Alternating 544Hz (100ms) / 440Hz (400ms) - NFS 32-001	1 1 1 0 1	Tone 31	Tone 27
Tone 41	Motor Siren - Slow rise to 1200Hz	0 0 0 1 1	Tone 2	Tone 5
Tone 42	Motor Siren - Slow rise to 800Hz	1 0 0 1 1	Tone 2	Tone 5
Tone 43	Continuous 1200Hz	0 1 0 1 1	Tone 2	Tone 5
Tone 44	Motor Siren - Slow rise to 2400Hz	1 1 0 1 1	Tone 2	Tone 5
Tone 45	Intermittent 1000Hz 1s ON, 1s OFF	0 0 1 1 1	Tone 38	Tone 34
Tone 46	Sawtooth 1200/500Hz @ 1Hz - D.I.N. (PFER P.T.A.F)	1 0 1 1 1	Tone 47	Tone 37
Tone 47	Intermittent 1000Hz 1s ON, 1s OFF - PFER General Alarm	0 1 1 1 1	Tone 46	Tone 37
Tone 48	420Hz @ 0.625s - Australian Alert	1 1 1 1 1	Tone 49	Tone 5
Tone 49	500-1200Hz 3.75s / 0.25s - Australian Evacuative	0 0 0 1 1	Tone 26	Tone 37

DIMENSIONS (mm)

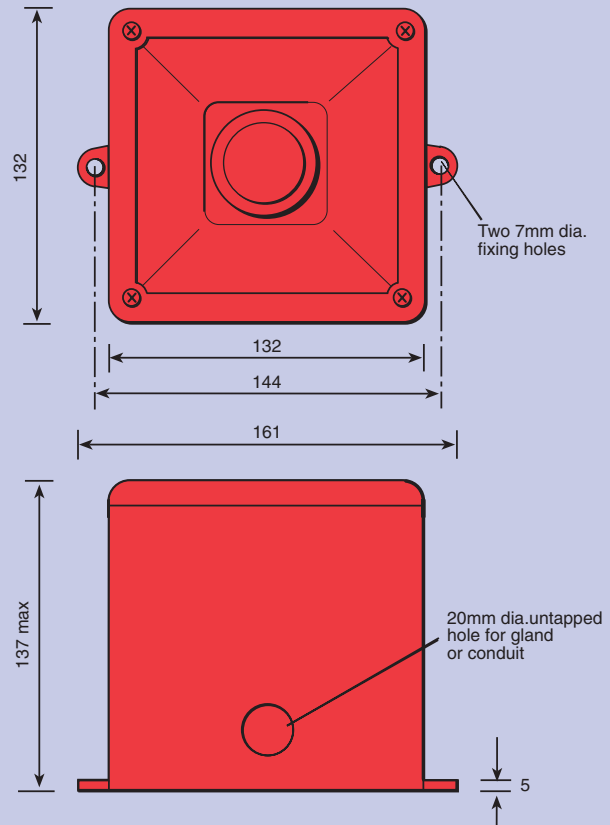

TERMINAL CONNECTIONS

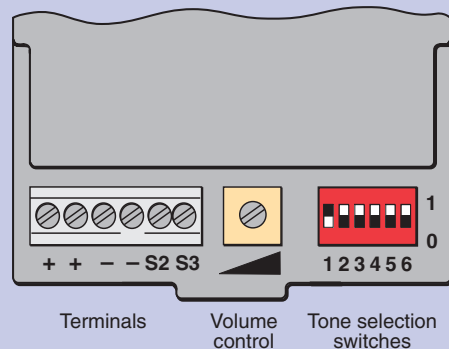

Environmental

Operating temp -40 to 60°C
Storage temp -40 to 85°C
Humidity To 95% @ 40°C
Enclosure IP66
EMC In accordance with EU Directive 89/336/EEC

Mechanical

Terminals Screw clamp for 0.5 to 2.5 mm² cable.
Weight 0.75 kg

Accessories

Tag number Thermally printed tag strip

Comm-Co B.V.

Kreekzoom 9, 4561 GX, Hulst

The Netherlands

Tel: +31 114-370030

Email: info@comm-co.com

COMM-CO
Communication today and tomorrow